

Low Lift Examination Table - N° TA301

This examination table is entirely constructed from high grade stainless steel to ensure a long life durability and an absolute hygiene.

With its foot switch and its height adjustable by electric actuator, you can use this exam table with ease - it enables you to work in an ergonomic way to avoid back injuries.

Very stable due to its X-frame design, this veterinary table makes smooth up-and-down operations and allows to safely examine animals up to 100 KG.

Features:

- Electric foot switch
- Electric actuator for smooth and silent up-and-down operations
- Pads of stability
- X-frame design for maximum stability
- Entirely in 304 L stainless steel
- Stainless steel top with height adjustment from 37 to 100 cm
- Tie-down hooks
- All electrics are certified for EU standards
- 5 years warranty for the frame
- 2 years warranty for electric parts

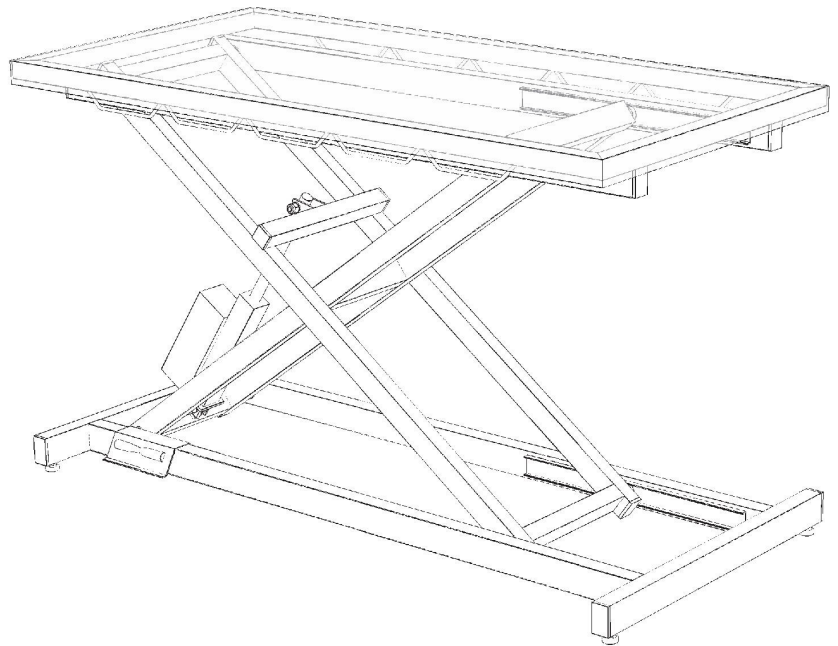

Dimensions:

- Table top : 125 x 60 cm
 - Minimal height : 37 cm
 - Maximal height : 100 cm
 - Charge maximum : 100 KG
- Custom sizes can be made to order*

Options :

- TA 301000 - Low lift examination table with stainless steel top
- TA 301010 - Low lift examination table with carpet and frame top
- TA 301200 - Low lift examination table with 2 drainings on top



ZAC du Pont des Nautes - 03410 SAINT VICTOR

Tél : 04 70 03 31 31 - Fax : 04 70 03 03 07

E-mail : contact@vetinox.fr

www.vetinox.fr



Low Lift Examination Table - N° TA301

Please read carefully the user manual before operating the device

First of all, don't forget to activate your warranty directly on our website www.vetinox.fr - tab Product Warranty.
Then, let yourself be guided to register your device.

• **Set-up - Activation**

- Carefully unpack the device
- Remove the foam wedges
- Connect the table to a power socket protected by a residual-current circuit breaker
- To lift the table, simply press the foot switch with an arrow up
- To lower the table, simply press the foot switch with an arrow down

• **Maintenance - in case of failure**

- A warranty of 5 years is offered to cover mechanical defects or corrosion as well as a warranty of 2 years for electric parts.
- This is a geared motor actuator - power 220 Volts - 400 Watts. It consists of the actuator itself on which is clipped the control box linked to a foot switch.
- Current-power = 220-240 volts.

Your table does not rise or lower anymore :

- Check if the power cable is properly connected or if it has not been severed.
- Check your circuit breaker on your power switchboard.
- If in spite of all these checks, your table will not operate, please contact us, we will be pleased to take care of your problem.

• **Contraindications**

- Do not immerse the table or wash it with a high pressure spray - shock hazards
- Do not exceed the maximum authorized weight
- Maximum allowable weight : 100 KG
- Connect the device to a secure electrical network
- Do not change the existing frame or the electrical system and in general do not make any modification
- Install the device in a suitable clean place

• **Cleaning and precautions for use**

The stainless steel used is type 304 L. This stainless steel has a very high resistance to corrosion. As stainless steel is a solid material and not a surface coating, the appearance of stains or traces may not be linked to rust in any case.

You can clean and restore the brushed appearance with a synthetic scouring pad, like green Scotch-Brit, by scrubbing lightly with the grain. Do not use steel wool. Ban all products in cream formulation which might clog or bleach and chlorine - based cleaners. It is better to favor glass products or quaternary ammonium.

If you have any doubt, please send us a photo of the cleaning product composition to confirm use.



ZAC du Pont des Nautes - 03410 SAINT VICTOR

Tél : 04 70 03 31 31 - Fax : 04 70 03 03 07

E-mail : contact@vetinox.fr

www.vetinox.fr

